

6224 29th Street SE  
 Calgary, Alberta T2C 1W3  
 TEL (403) 236-7738  
 FAX (403) 287-7728

NO.	DATE			REVISION	BY
	D	MO	YR.		
D	MO	YR.	ISSUED FOR		BY

CLIENT INFO

MV SERIES  
 BUILDING  
 12'Wx8'Lx8'H

QTY:

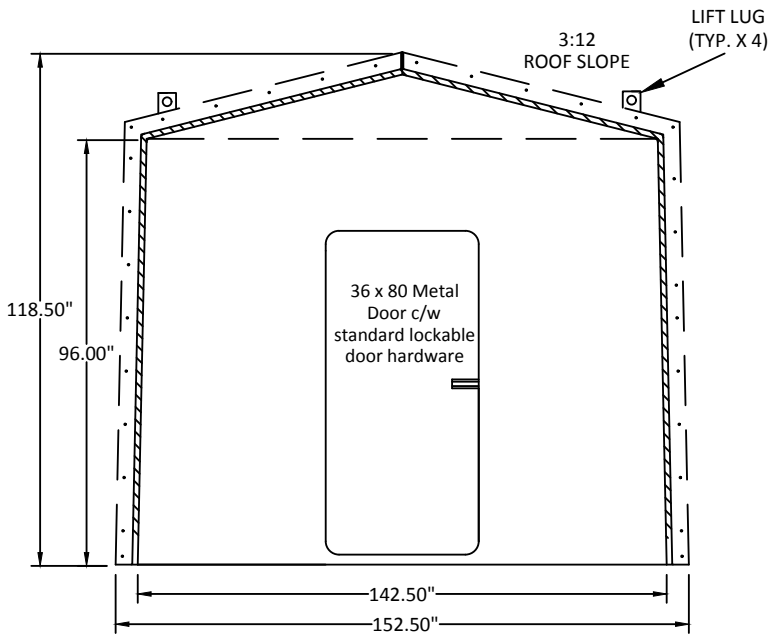

**FRONT ELEV.**

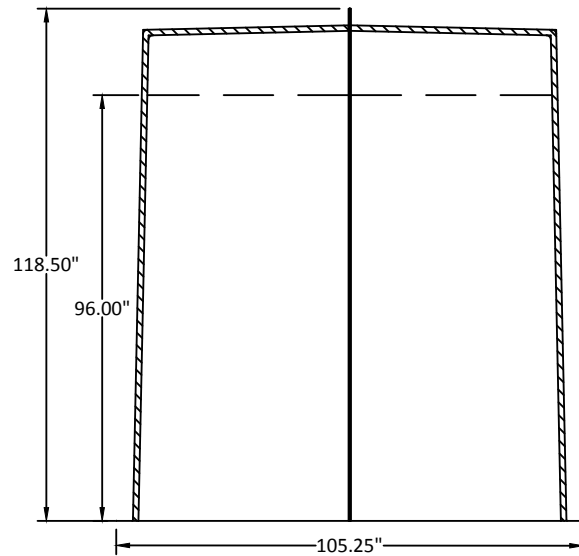

**RIGHT ELEV.**

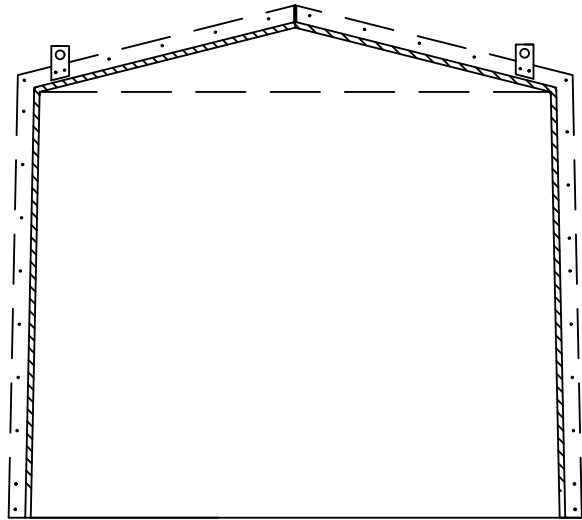
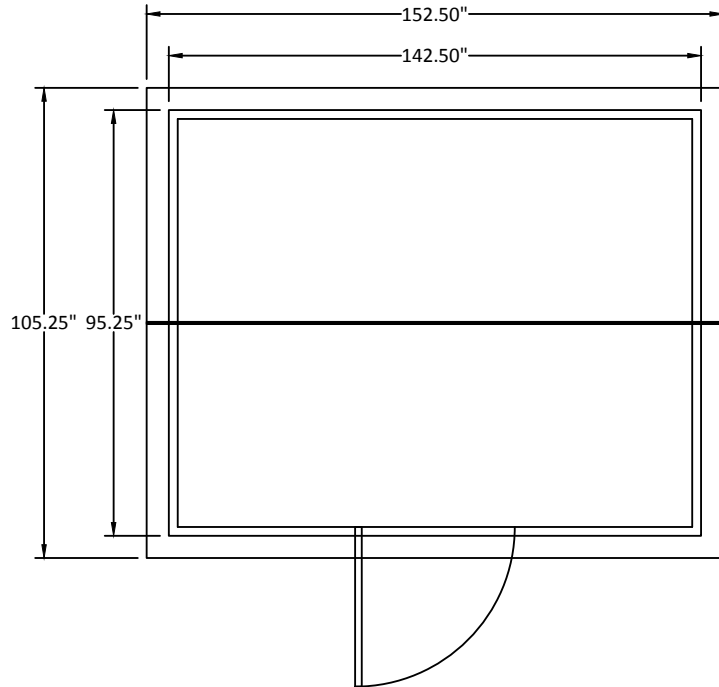

**REAR ELEV.**

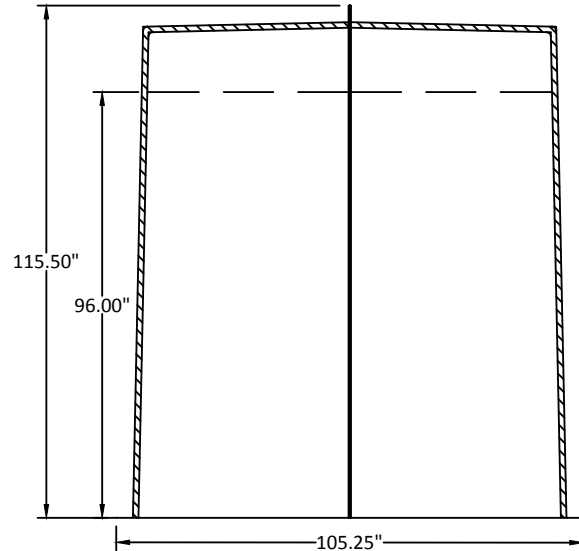

**LEFT ELEV.**

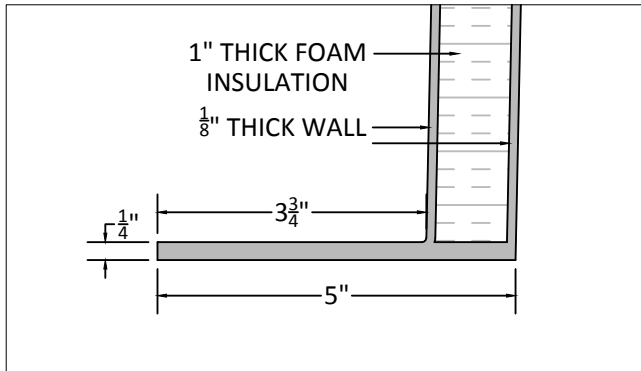

**EXTERNAL FLANGE DETAIL**

-ALL MEASUREMENTS ARE NOMINAL

DRAWN BY MW	REVIEWED BY REVIEWED
SCALE NTS	DATE 2019/04/16
CLIENT APPROVAL	
SIGNATURE	
DATE	
ISSUE FOR APPROVAL	PROJECT NO. --

MV12'WX8'LX8'H