

PLAN

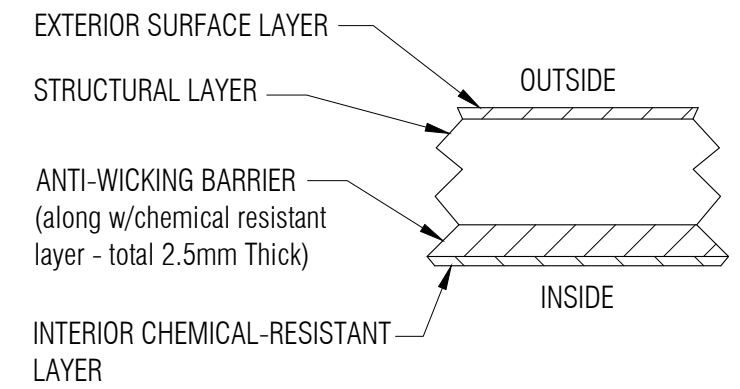

LAMINATE DETAIL 1
NTS

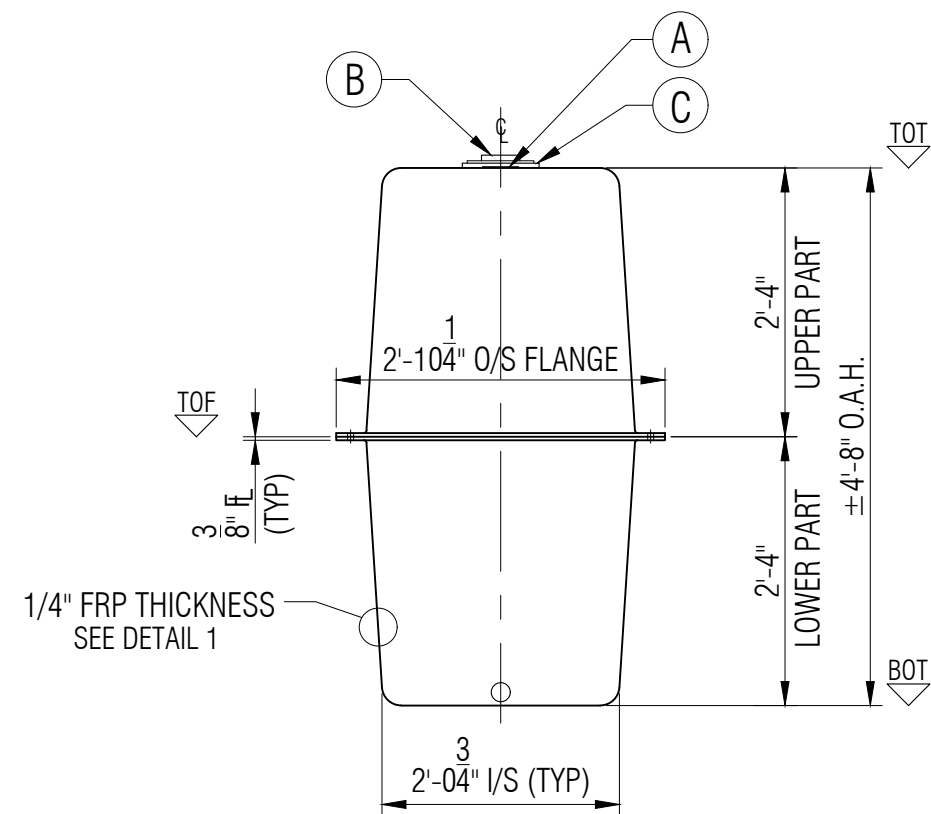

ELEVATION A

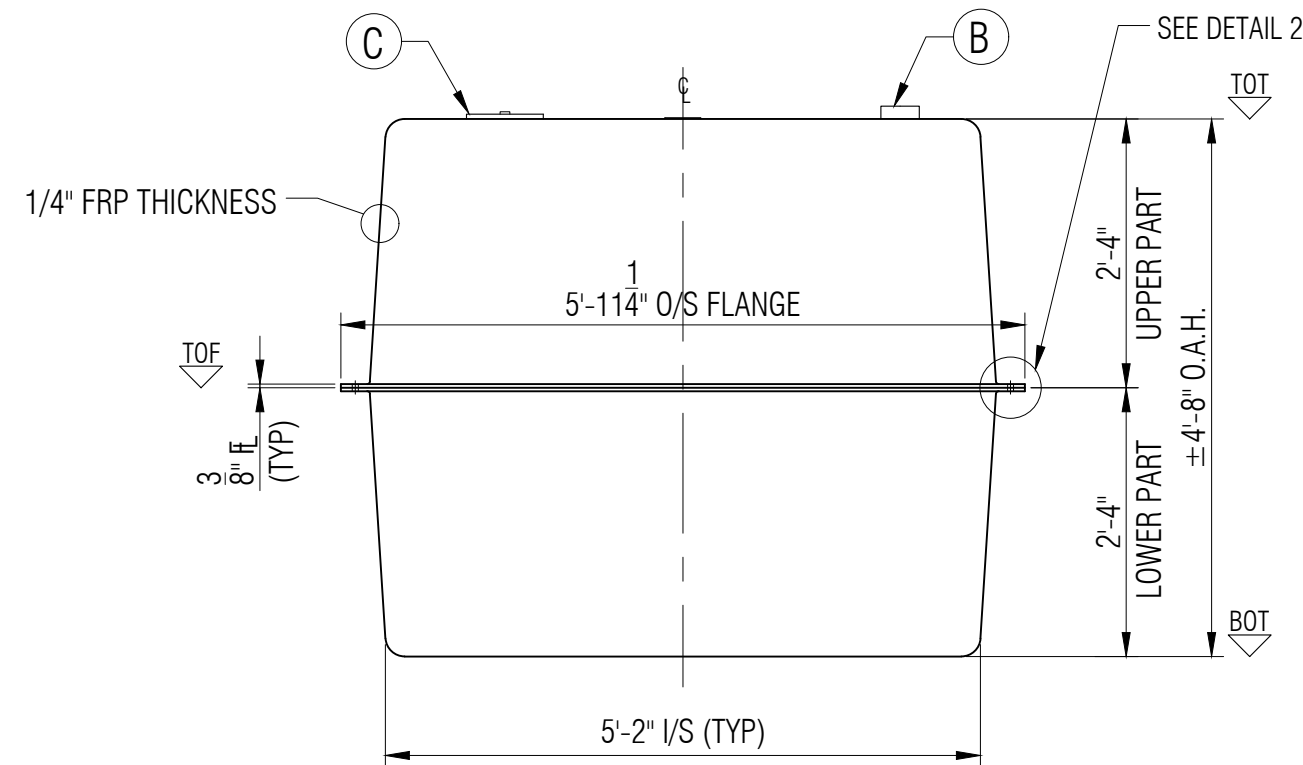

ELEVATION B

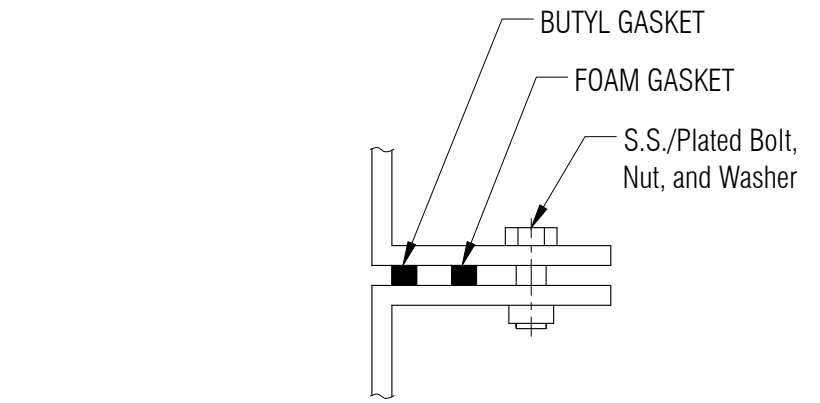

FLANGE TO FLANGE CONNECTION DETAIL 2
NTS

LEGEND:
 TOT - TOP OF TANK
 TOF - TOP OF FLANGE
 BCD - BOLT CENETR DIAMETER
 BOT - BOTTOM OF TANK
 I/S - INSIDE
 O.A.H.-OVERALL HEIGHT
 O.A.L.-OVERALL LENGTH
 I/S - INSIDE
 O/S - OUTSIDE
 Ø - DIAMETER
 ° - DEGREE/S
 TYP- TYPICAL
 CL - CENTER LINE
 NTS - NOT TO SCALE

GENERAL NOTES:
 - CSA B66 CERTIFIED FOR SEWAGE.
 - TANK COMES UNASSEMBLED FROM FACTORY.
 - DIMENSIONS SHOWN IN FEET INCHES FORMAT OTHERWISE NOTED.
 - 1/2" FABRICATION TOLERANCE. DOES NOT APPLY TO LAMINATE THICKNESS.

ITEM#	QTY	PART LIST/DESCRIPTION	APPROX. WEIGHT:	73KG (160LBS.)	DRAWN:	ATF	CLIENT:	FRP/MOCOAT FIBERGLASS LTD.
A	1	NAMEPLATE	OVERALL CAPACITY:	1,364 L (300 IG/360 USG)	CHECKED:		TITLE:	AGS-300-OV SEWAGE STORAGE TANK
B	1	4"Ø PVC-DWV COUPLING - INLET			DATE:	NOV. 30, 2023		FRP MOCOAT FIBERGLASS LTD.
C	1	8"Ø NON-VENTED POLY LID			DESIGNED:			
D					APPROVED:	MPS	SIZE:	C
E					MFG:	DS	DRAWING NUMBER:	AGS-300-OV
F					PM:	GA	SCALE:	1:20
G					SALES:	DG	EST#:	
							SO#:	
							PO#:	
							JOB#:	
							REVISION	0
							SHEET	1/1