

**PLAN**

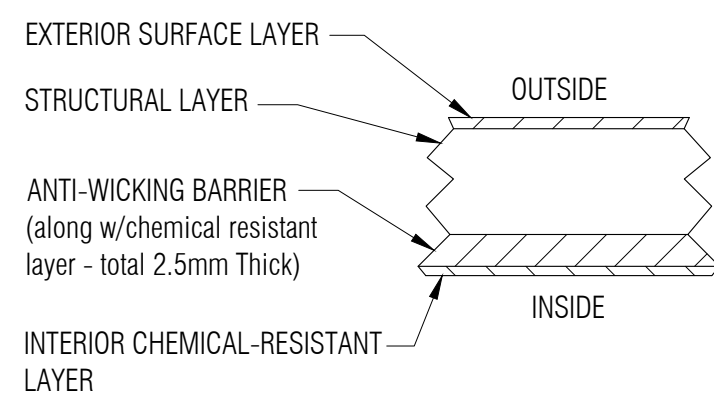

**LAMINATE DETAIL 1**  
NTS

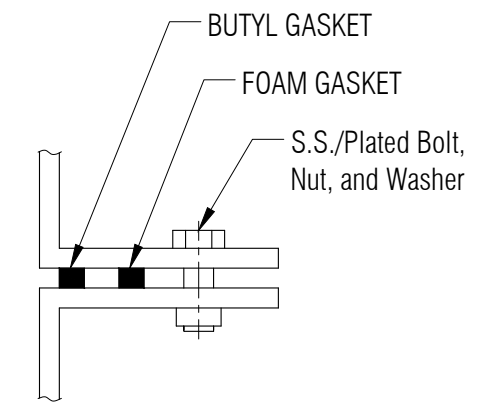

**FLANGE TO FLANGE CONNECTION DETAIL 2**  
NTS

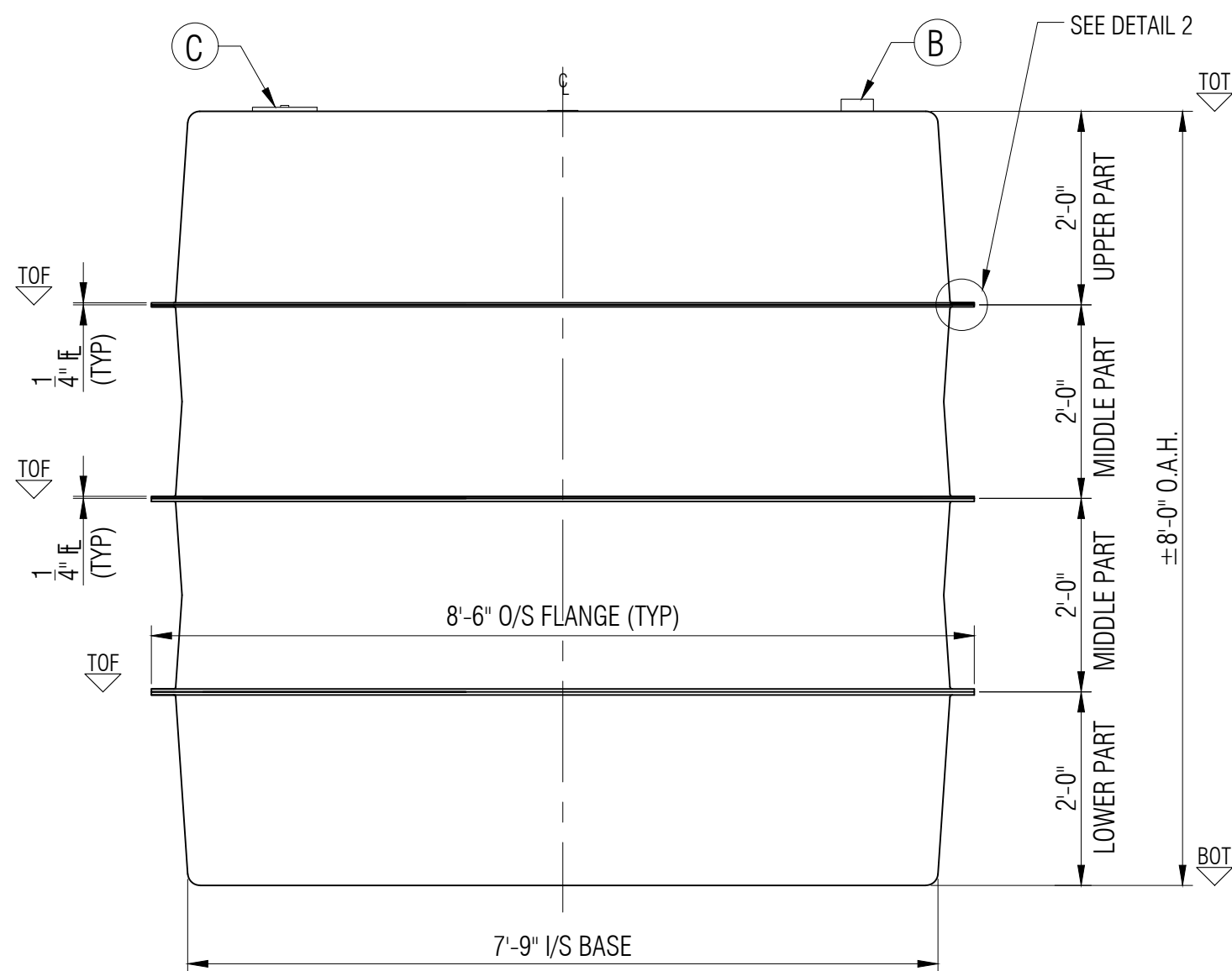

**ELEVATION A**

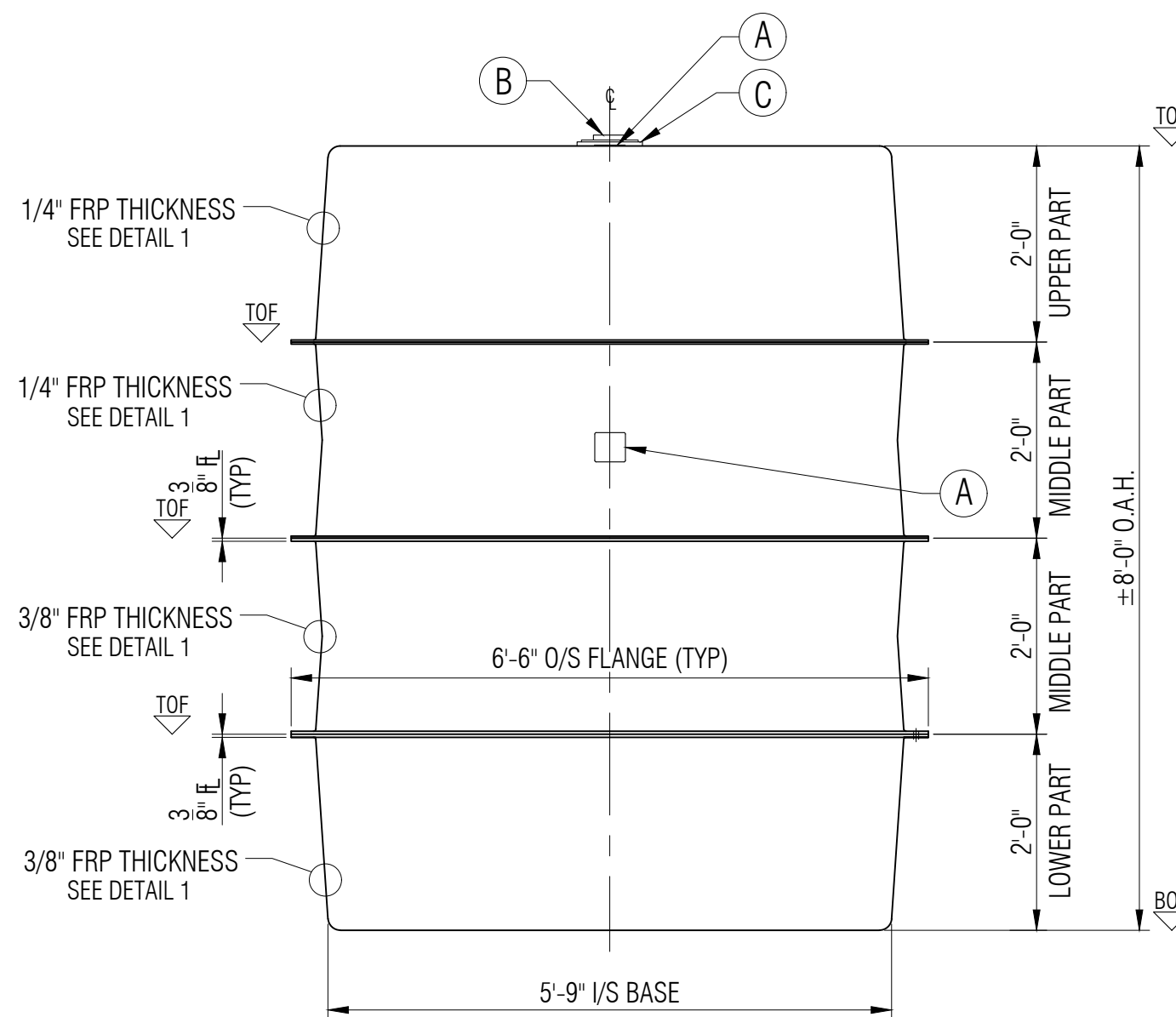

**ELEVATION B**

- LEGEND:  
 TOT - TOP OF TANK  
 TOF - TOP OF FLANGE  
 BCD - BOLT CENETR DIAMETER  
 BOT - BOTTOM OF TANK  
 I/S - INSIDE  
 O.A.H.-OVERALL HEIGHT  
 O.A.L.-OVERALL LENGTH  
 I/S - INSIDE  
 O/S - OUTSIDE  
 Ø - DIAMETER  
 ° - DEGREE/S  
 TYP- TYPICAL  
 CL - CENTER LINE  
 NTS - NOT TO SCALE

GENERAL NOTES:  
 - CSA B66 CERTIFIED FOR SEWAGE STORAGE TANK.  
 - TANK COMES UNASSEMBLED FROM FACTORY.  
 - DIMENSIONS SHOWN IN FEET INCHES FORMAT OTHERWISE NOTED.  
 - 1/2" FABRICATION TOLERANCE. DOES NOT APPLY TO LAMINATE THICKNESS.

ITEM#	QTY	PART LIST/DESCRIPTION	APPROX. WEIGHT:	374KG (825LBS.)	DRAWN:	ATF	CLIENT:	FRP/MOCOAT FIBERGLASS LTD.			
A	1	NAMEPLATE	OVERALL CAPACITY:	9,092 L (2,000 IG/2,400 USG)	CHECKED:		TITLE:	<b>AGS-2000-OV SEWAGE STORAGE TANK</b>			
B	1	4"Ø PVC-DWV COUPLING - INLET			DATE:	FEB. 02, 2023		<b>FRP MOCOAT</b> FIBERGLASS LTD.			
C	1	8"Ø NON-VENTED POLY LID			DESIGNED:						
D					APPROVED:	MPS	SIZE:	C			
E					MFG:	DS	DRAWING NUMBER:	AGS-2000-OV			
F					PM:	GA	EST#:				
G					SALES:	DG	PO#:				
							SCALE:	1:20	REVISION:	0	
								SO#:		SHEET:	1/1
								JOB#:			