

1 2 3 4 5 6

A

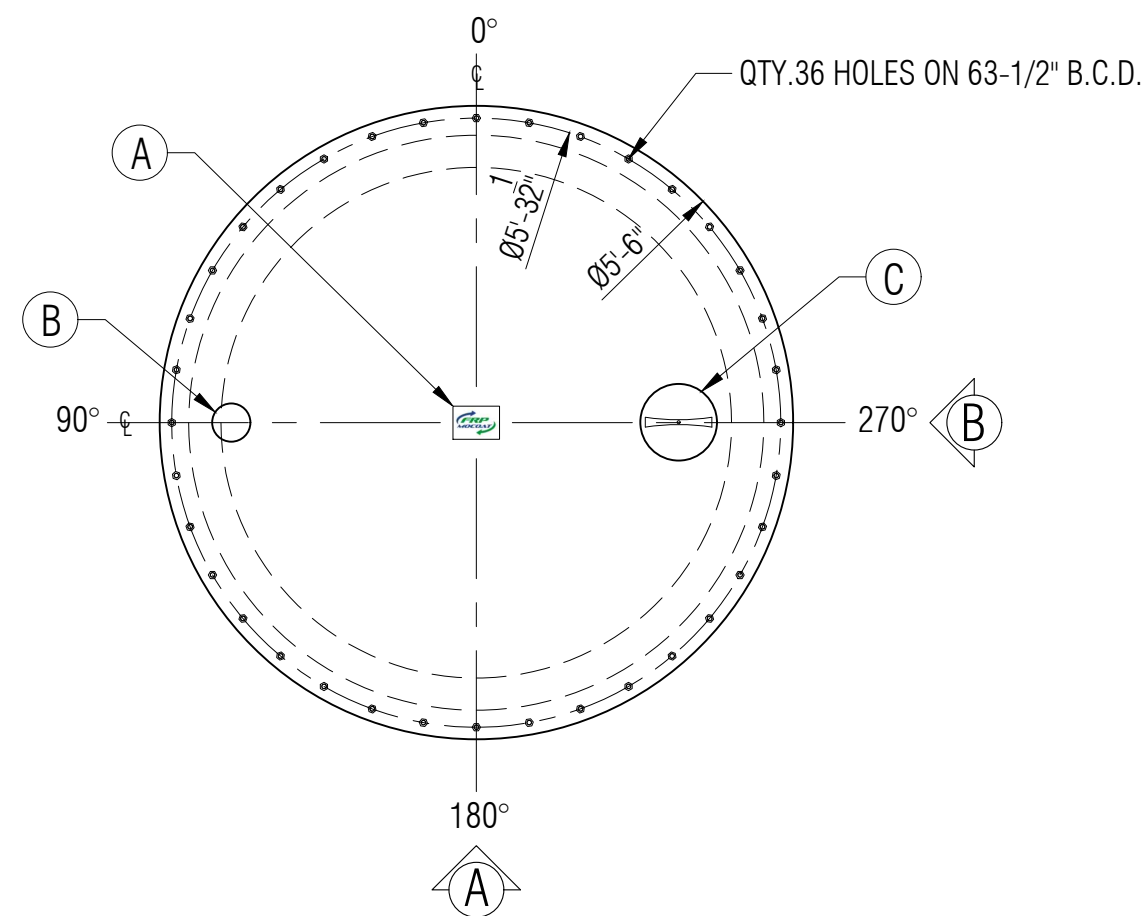

PLAN

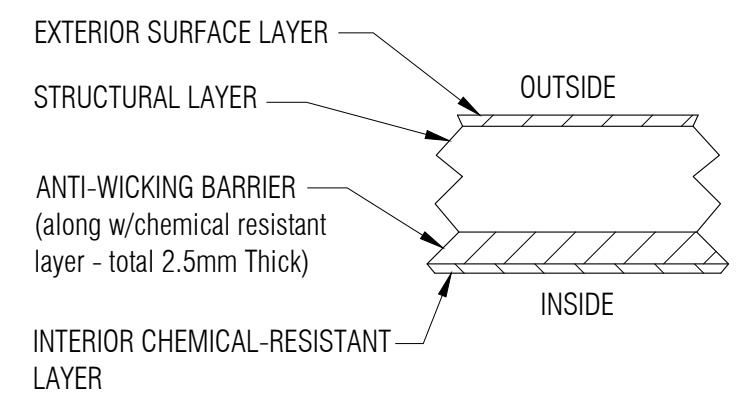

LAMINATE DETAIL 1
NTS

B

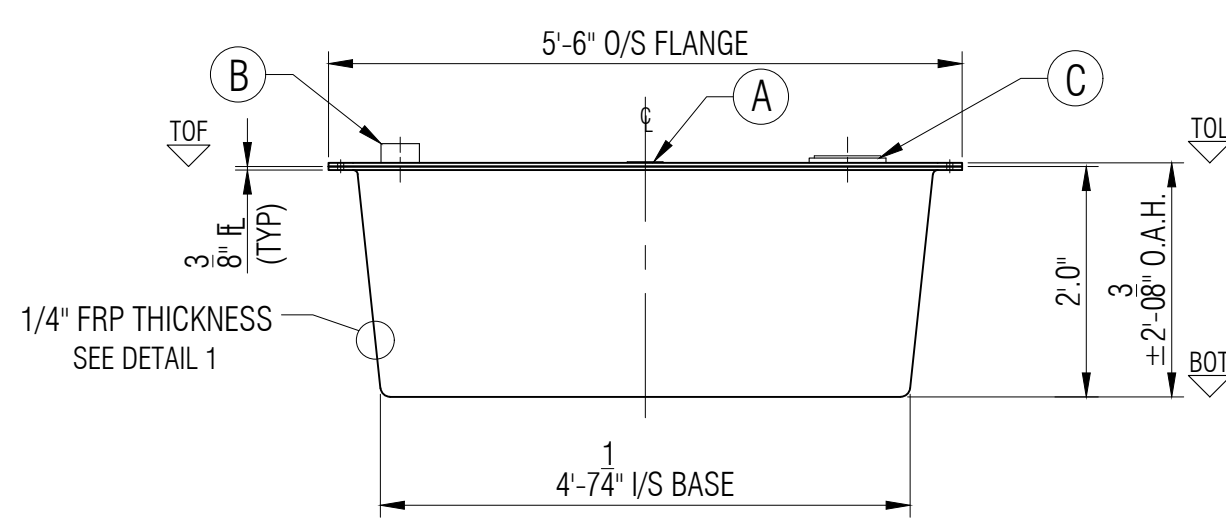

ELEVATION A

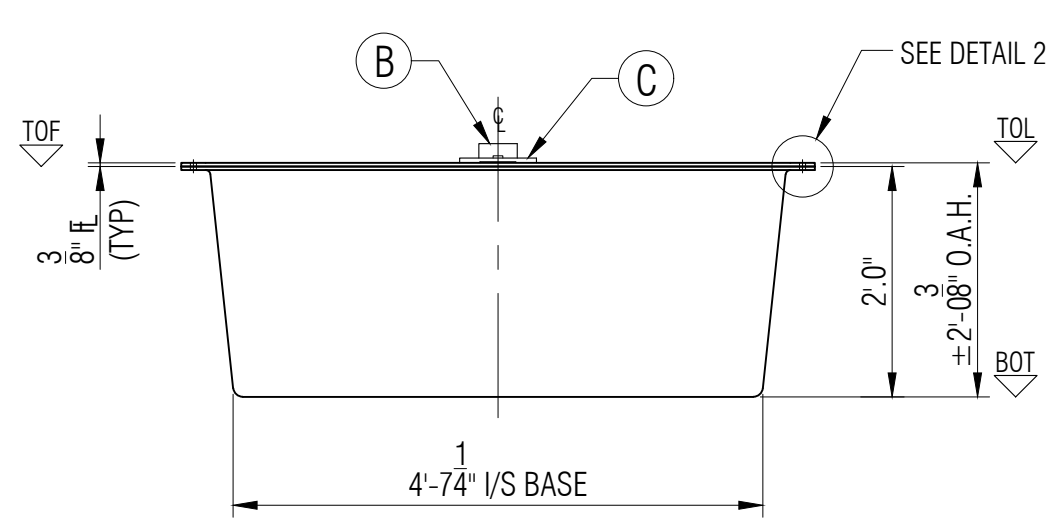

ELEVATION B

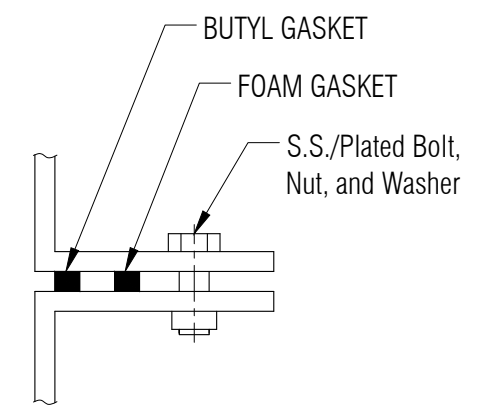

FLANGE TO FLANGE CONNECTION DETAIL 2
NTS

C

LEGEND:
 TOL - TOP OF LID
 TOF - TOP OF FLANGE
 BCD - BOLT CENETR DIAMETER
 BOT - BOTTOM OF TANK
 I/S - INSIDE
 O.A.H.-OVERALL HEIGHT
 O.A.L.-OVERALL LENGTH
 I/S - INSIDE
 O/S - OUTSIDE
 Ø - DIAMETER
 ° - DEGREE/S
 TYP- TYPICAL
 CL - CENTER LINE
 NTS - NOT TO SCALE

GENERAL NOTES:
 - CSA B66 CERTIFIED SEWAGE HOLDING TANK.
 - TANK COMES UNASSEMBLED FROM FACTORY.
 - DIMENSIONS SHOWN IN FEET INCHES FORMAT OTHERWISE NOTED.
 - 1/2" FABRICATION TOLERANCE. DOES NOT APPLY TO LAMINATE THICKNESS.

ITEM#	QTY	PART LIST/DESCRIPTION	APPROX. WEIGHT:	61 KG (135 LBS.)	DRAWN:	ATF	CLIENT:	FRP/MOCOAT FIBERGLASS LTD.
A	1	NAMEPLATE	OVERALL CAPACITY:	1,137 L (250 IG/300 USG)	CHECKED:		TITLE:	AGS250-RD SEWAGE HOLDING TANK
B	1	4"Ø PVC-DWV COUPLING - INLET			DATE:	JAN. 02, 2024		
C	1	8"Ø NON-VENTED POLY LID			DESIGNED:			
D					APPROVED:	MPS	SIZE:	C
E					MFG:	DS	DRAWING NUMBER:	AGS250-RD
F					PM:	GA	EST#:	
G					SALES:	DG	PO#:	
							SCALE:	1:20
							SO#:	
							JOB#:	
							REVISION:	0
							SHEET:	1/1

1 2 3 4 5 6

A

B

C

D