



**AGW2500-OV  
FIBREGLASS WATER STORAGE TANK**

Overall Weight: Approx. 397 kg (874 lbs)

Capacity: Approx. 11,365 L (2,500 Imp Gal, 3,000 US Gal)



Drinking Water  
NSF/ANSI 61

**TOP VIEW**

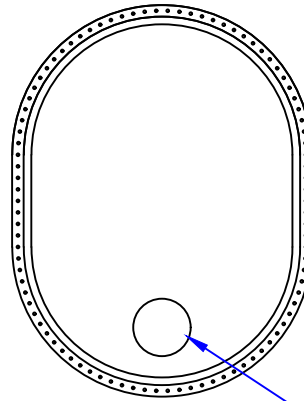

15" Dia. Poly Vented Lid

**LAMINATE DETAIL**

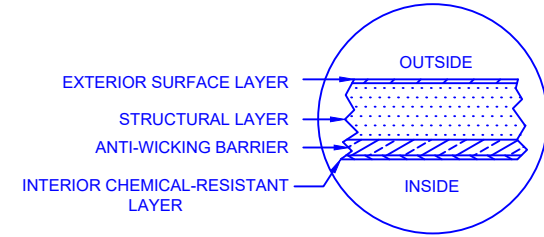

**FLANGE CONNECTION DETAIL**

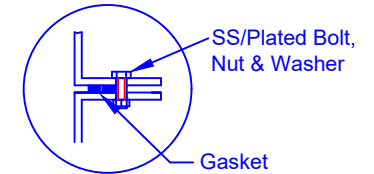

**Notes:**

- Bottom two (2) sections are Heavy Duty.
- Various inlet & outlet fittings available including bulkhead fittings, couplings, pipe, flanged fittings, vents, etc. at extra cost.
- Tank comes unassembled (Tank can be assembled at factory at extra cost)

**END VIEW**

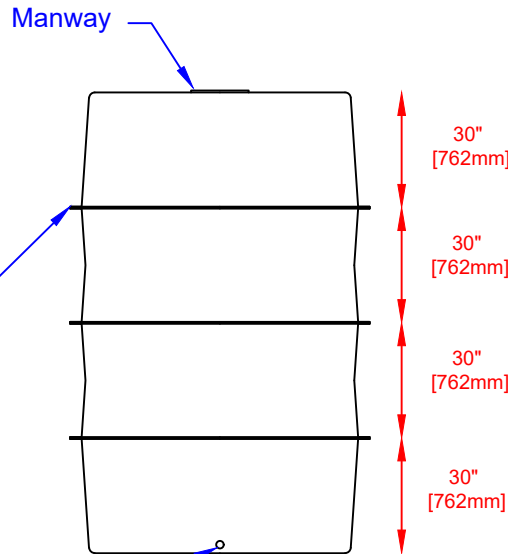

1 1/4" NPT Female Bulkhead can be located on side or on end

6'-6"  
[1981mm]

**SIDE VIEW**

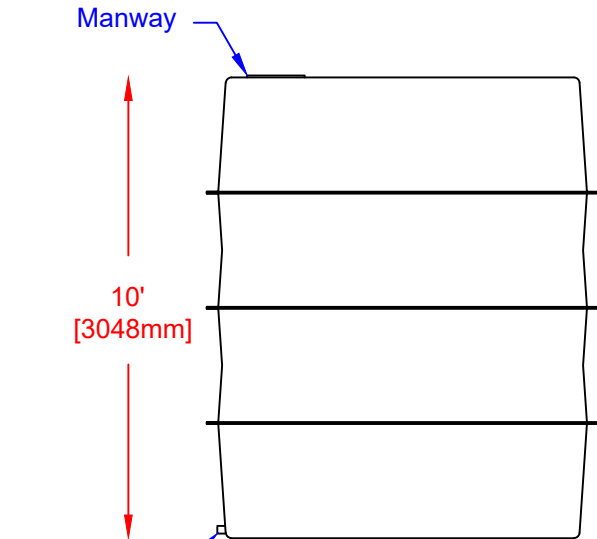

Outlet

8'-6"  
[2591mm]