

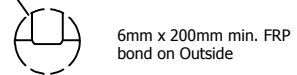

Parts List			
ITEM	QTY	PART NUMBER	DESCRIPTION
1	1	C-COLLAR-30IN	30"D COLLAR
2	1	C-LID-30IN-STD	30"D STANDARD LID
3	4	LIFT-LUG-8-10	LIFT LUG
4	4	C-RIB-GUIDE	STURUCTURAL RIB WITH ANCHOR GUIDE
5	11	C-RIB	STRUCTURAL RIB
6	1	C-SEAM-10FT	SEAM

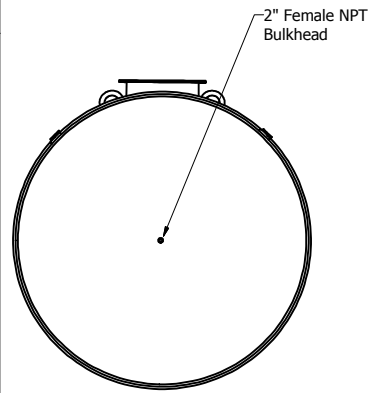
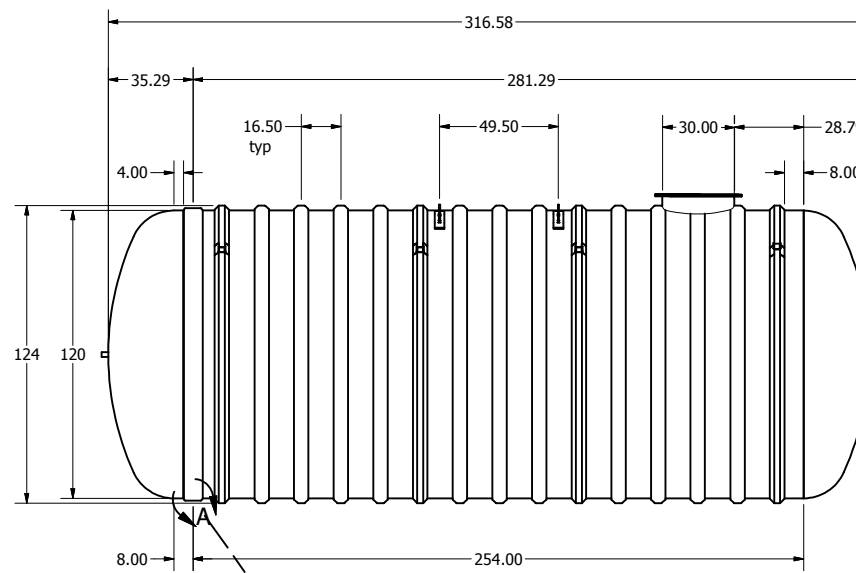
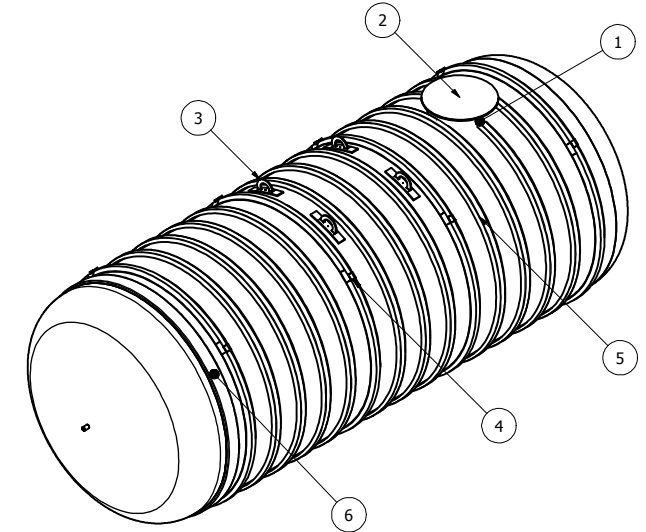
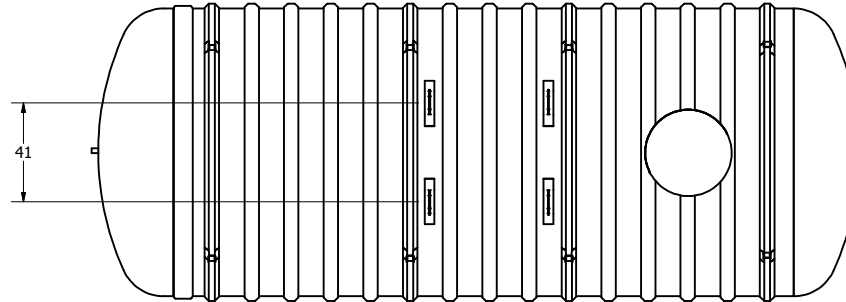

SECTIONAL JOINT DETAIL A
SCALE 1/25

OPTIONAL	PARTS
<input type="checkbox"/> 30"X12" EXTENSION	<input type="checkbox"/> ANCHORS
<input type="checkbox"/> 30"X30" EXTENSION	<input type="checkbox"/> FOAM INSULATION
<input type="checkbox"/> 30"X60" EXTENSION	<input type="checkbox"/> LOCK BAR
<input type="checkbox"/> 30"X84" EXTENSION	<input type="checkbox"/> OPTIONAL FITTING(S)
<input type="checkbox"/> ALARM	<input type="checkbox"/> PUMP STAND

DRAWN	MPS	7/19/2022
CHECKED		
QA		
MFG		
DCL		
APPROVED		
DCL		
WEIGHT	1,705 kg (3,750 lbs)	LENGTH
OVERALL CAPACITY	54,552L (12,000 IG, 14,400 USG)	26' 5"

TITLE		BX12000W UNDERGROUND FIBREGLASS WATER CISTERN	
 Drinking Water NSF/ANSI 61			
SIZE	C	DWG NO	BX12000W-00
SCALE		REV	
SHEET 1 OF 1			