

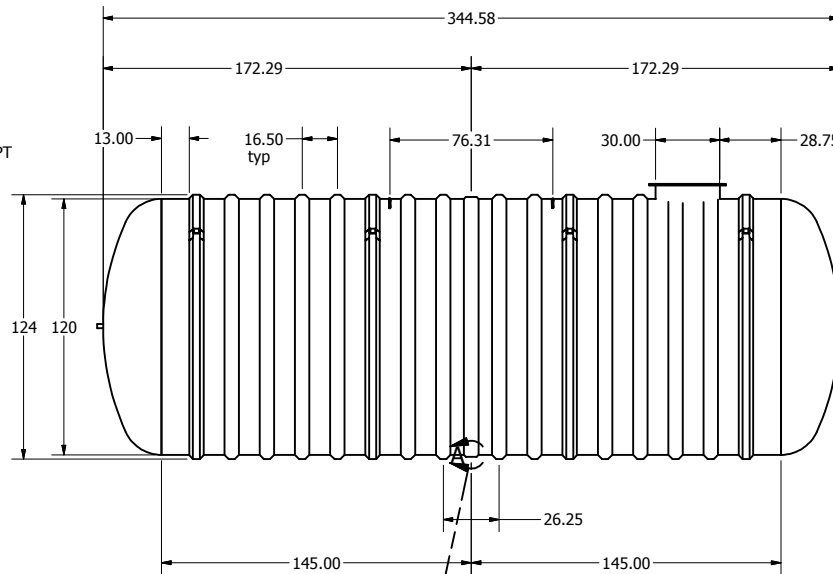

Parts List			
ITEM	QTY	PART NUMBER	DESCRIPTION
1	1	C-COLLAR-30IN	30"D COLLAR
3	1	SEAM-10FT	SEAM
2	4	LIFT-LUG-8-10	LIFT LUG
4	4	C-RIB-GUIDE	STURUCTURAL RIB WITH ANCHOR GUIDE
5	12	C-RIB	STRUCTURAL RIB

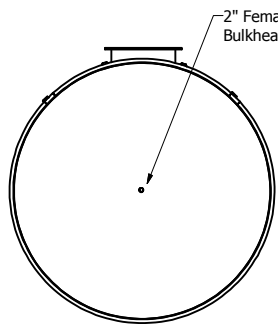
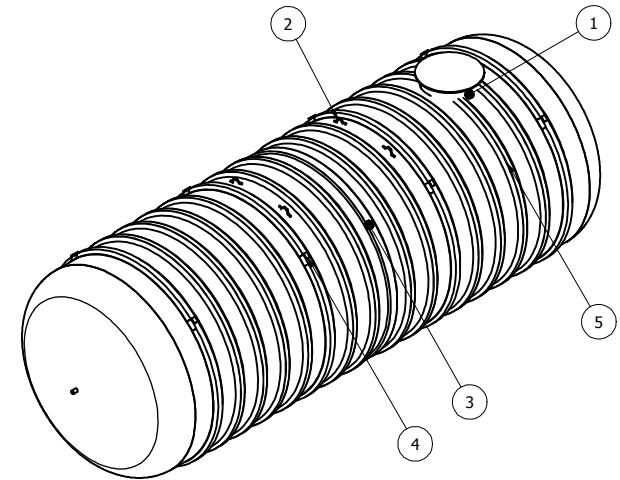
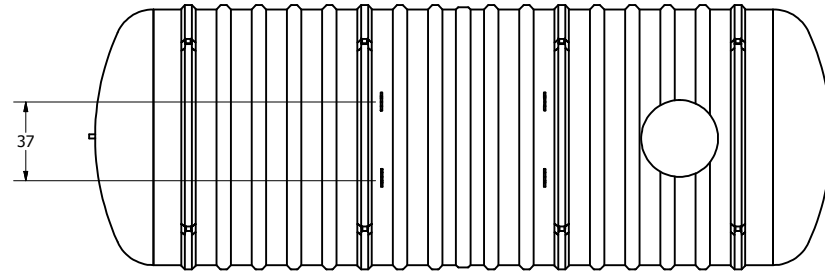

6mm x 200mm min. FRP bond on Outside

SECTIONAL JOINT DETAIL A
SCALE 1/25

OPTIONAL	PARTS
<input type="checkbox"/> 30"X12" EXTENSION	<input type="checkbox"/> ANCHORS
<input type="checkbox"/> 30"X30" EXTENSION	<input type="checkbox"/> FOAM INSULATION
<input type="checkbox"/> 30"X60" EXTENSION	<input type="checkbox"/> LOCK BAR
<input type="checkbox"/> 30"X84" EXTENSION	<input type="checkbox"/> OPTIONAL FITTING(S)
<input type="checkbox"/> ALARM	<input type="checkbox"/> PUMP STAND

DRAWN MPS	7/19/2022	TITLE BX13000W UNDERGROUND FIBREGLASS WATER CISTERN
CHECKED		
QA		
MFG DCL		 
APPROVED DCL		
CAPACITY 59,098L (13,000 IG)	LENGTH 28' 9"	SIZE C DWG NO BX13000W SCALE REV 1
		SHEET 1 OF 1