

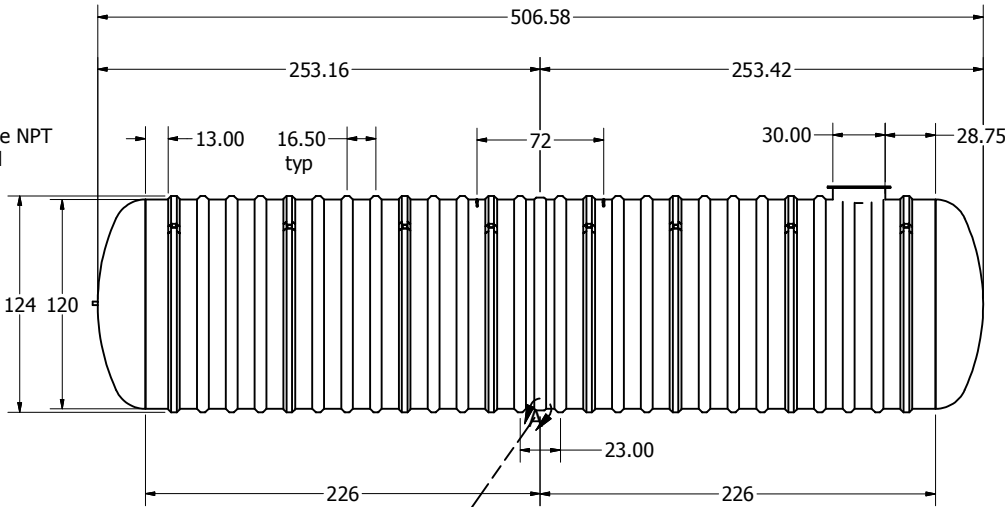

Parts List			
ITEM	QTY	PART NUMBER	DESCRIPTION
1	1	C-COLLAR-30IN	30"D COLLAR
2	4	LIFT-LUG-8-10	LIFT LUG
3	8	C-RIB-GUIDE	STURCTURAL RIB WITH ANCHOR GUIDE
4	18	C-RIB	STRUCTURAL RIB
5	1	SEAM-10FT	SEAM

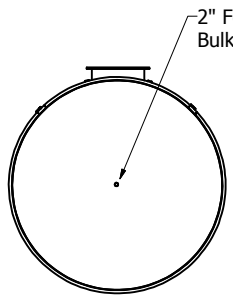
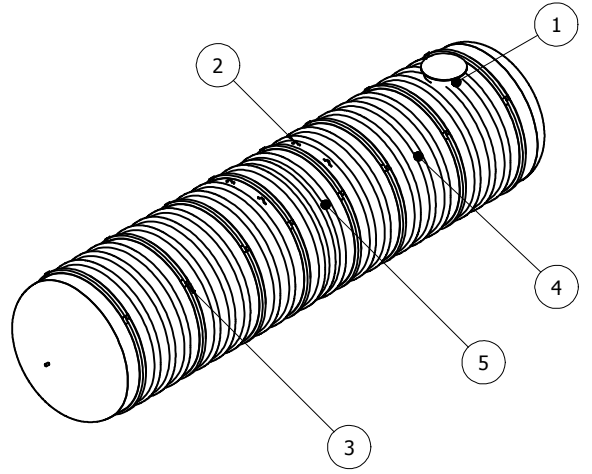
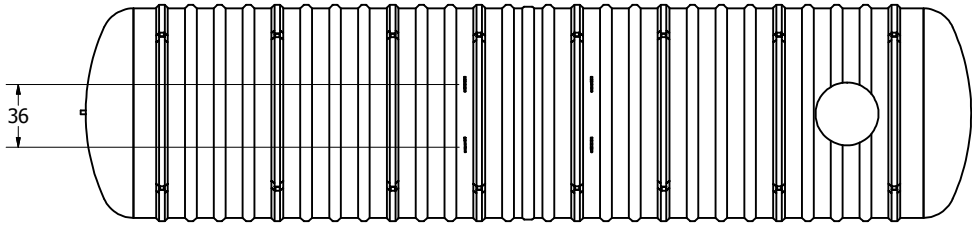

6mm x 200mm min. FRP bond on Outside

SECTIONAL JOINT DETAIL A  
SCALE 1/25

OPTIONAL	PARTS
30"X12" EXTENSION	ANCHORS
30"X30" EXTENSION	FOAM INSULATION
30"X60" EXTENSION	LOCK BAR
30"X84" EXTENSION	OPTIONAL FITTING(S)
ALARM	PUMP STAND

DRAWN MPS	7/19/2022	TITLE BX20000W UNDERGROUND FIBREGLASS WATER CISTERN	
CHECKED		 	
QA		Drinking Water NSF/ANSI 61	
MFG DCL		SIZE C	DWG NO BX20000W
APPROVED DCL		SCALE	REV 1
CAPACITY 90,920L (20,000 IG)	LENGTH 42' 3"	SHEET 1 OF 1	