

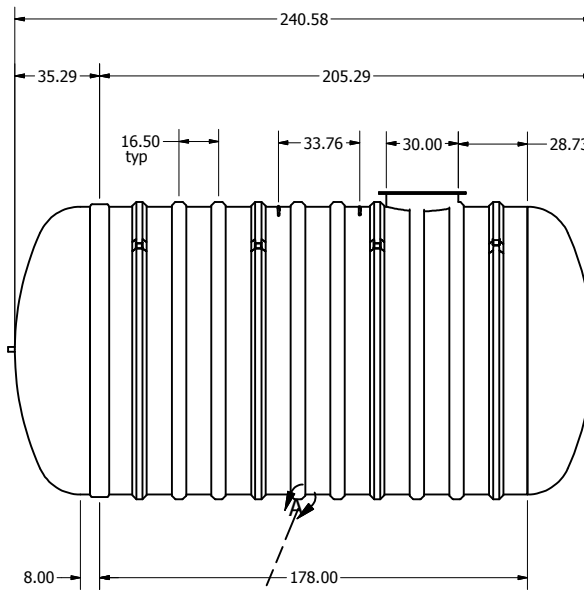

Parts List			
ITEM	QTY	PART NUMBER	DESCRIPTION
1	1	C-COLLAR-30IN	30"D COLLAR
2	1	C-SEAM-10FT	SEAM
3	4	LIFT-LUG-8-10	LIFT LUG
4	6	C-RIB	STRUCTURAL RIB
5	4	C-RIB-GUIDE	STRUCTURAL RIB WITH ANCHOR GUIDE

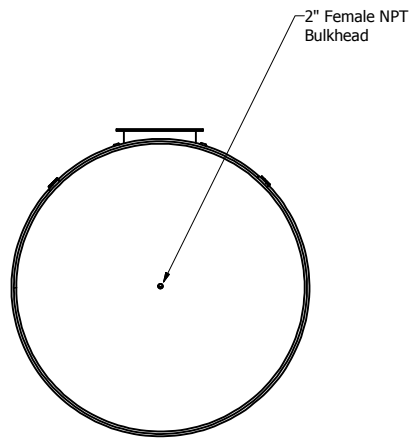
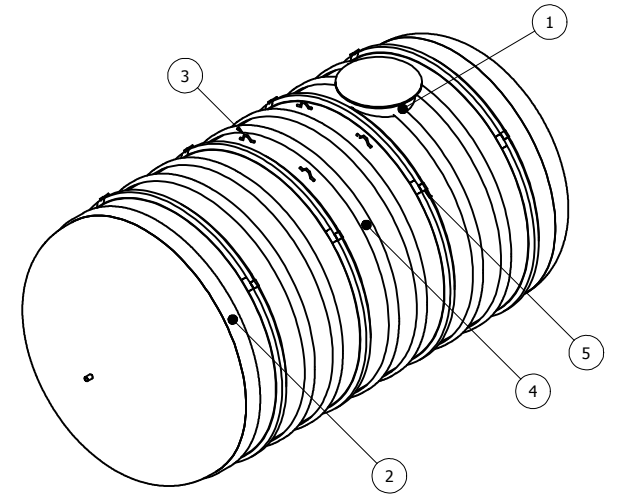
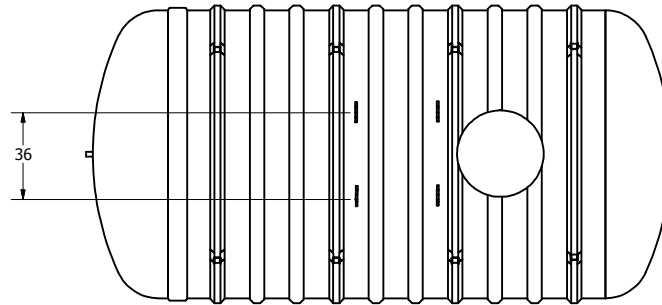

6mm x 200mm min. FRP bond on Outside

SECTIONAL JOINT DETAIL A
SCALE 1/25

OPTIONAL	PARTS
30"X12" EXTENSION	ANCHORS
30"X30" EXTENSION	FOAM INSULATION
30"X60" EXTENSION	LOCK BAR
30"X84" EXTENSION	OPTIONAL FITTING(S)
ALARM	PUMP STAND

DRAWN MPS	7/19/2022	TITLE BX9000W UNDERGROUND FIBREGLASS WATER CISTERN	
CHECKED			
QA			
MFG DCL		 	
APPROVED DCL		Drinking Water NSF/ANSI 61	
WEIGHT 1,364 kg (3,000 lbs)	LENGTH 20' 1"	SIZE C	DWG NO BX9000W
OVERALL CAPACITY 40,914L (9,000 IG, 10,800 USG)		SCALE	REV 1
		SHEET 1 OF 1	