

LABEL LOCATIONS

ITEM	QTY	DESCRIPTION	ITEM	QTY	DESCRIPTION
A	1	NAME PLATE	B	1	INLET
C	1	OUTLET	D	1	DANGER GAS
E	2	LIFTING HANDLE			

* TANK COMES FULLY ASSEMBLED FROM FACTORY *

* PVC FITTINGS ARE CSA CERTIFIED

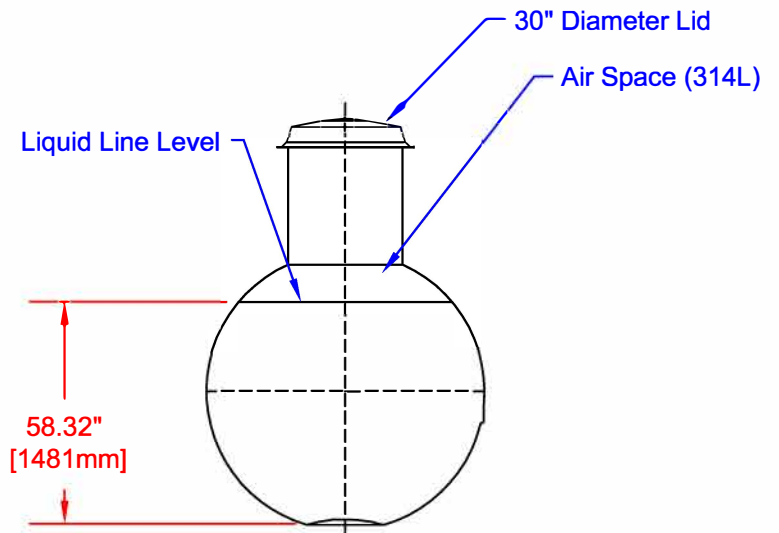
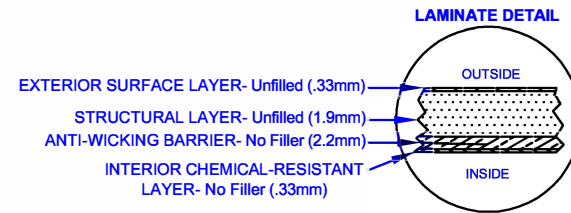
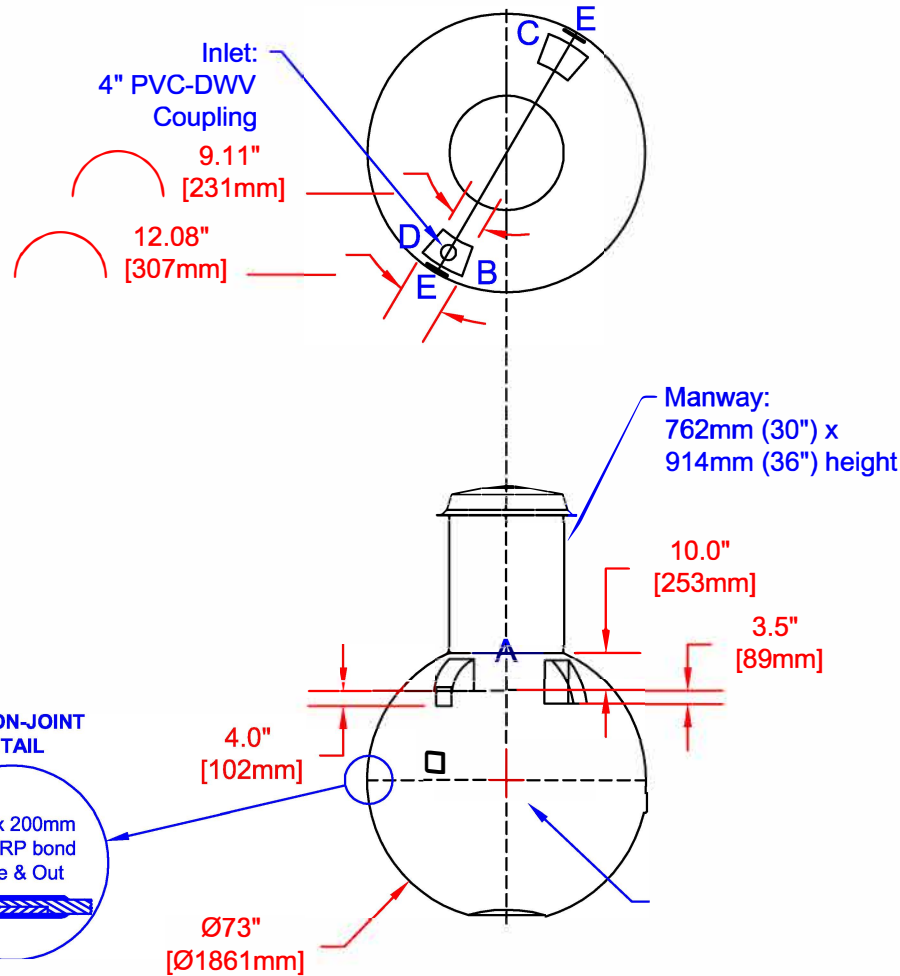

HB750 FIBREGLASS SEWAGE HOLDING TANK

Overall Diameter:	1,854mm (73")	Overall Weight:	136 kg (300 lbs)		
DATE:	07-13-2022	DATE:		DWG SCALE:	Overall Capacity: 3,337L (734 Imp Gal, 881 US Gal)
BY:	MARK SOLLID	APPROVAL:		REV:	A
					Holding Capacity: 2987L (657 Imp Gal, 788 US Gal)