

PLAN

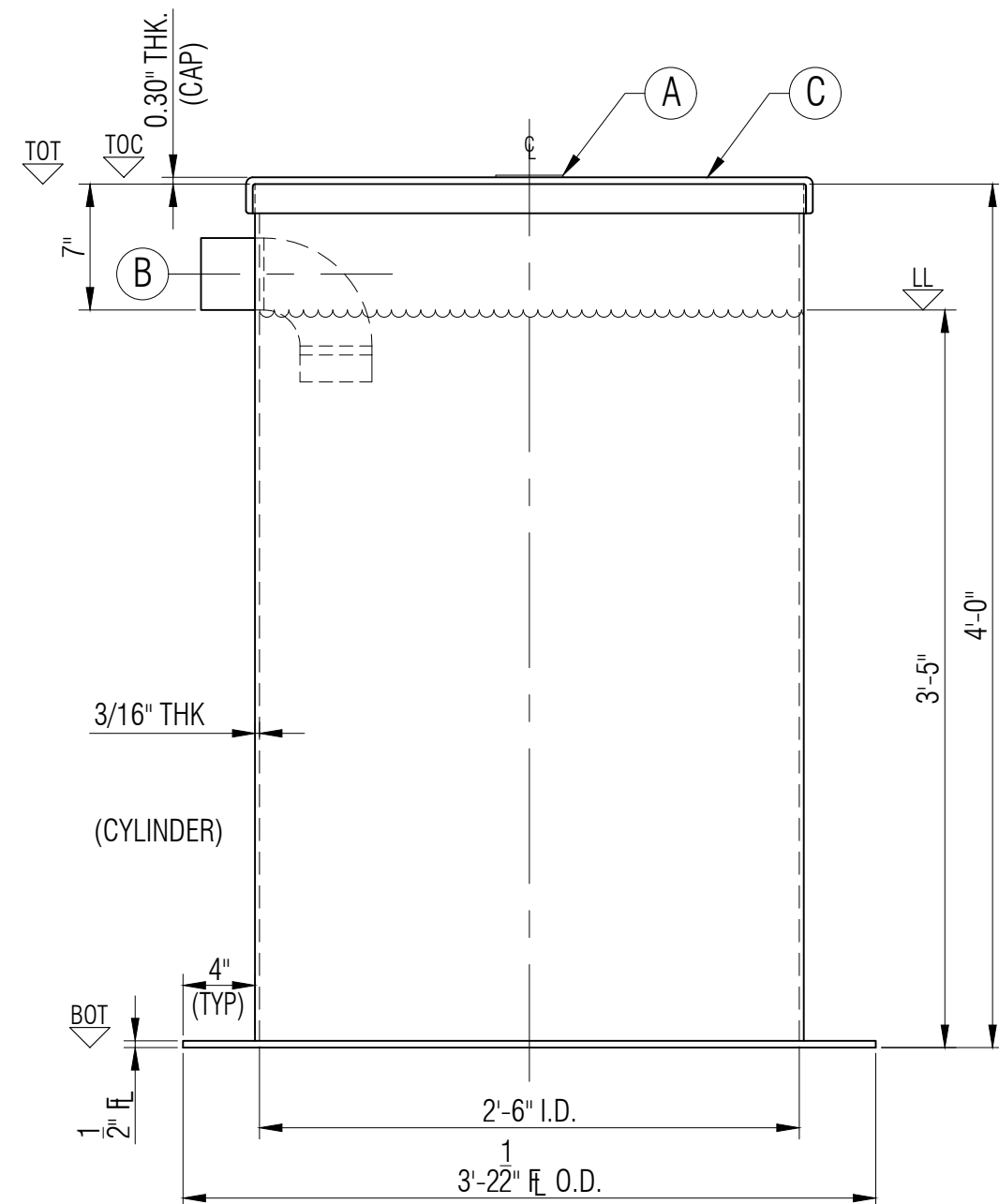

ELEVATION A

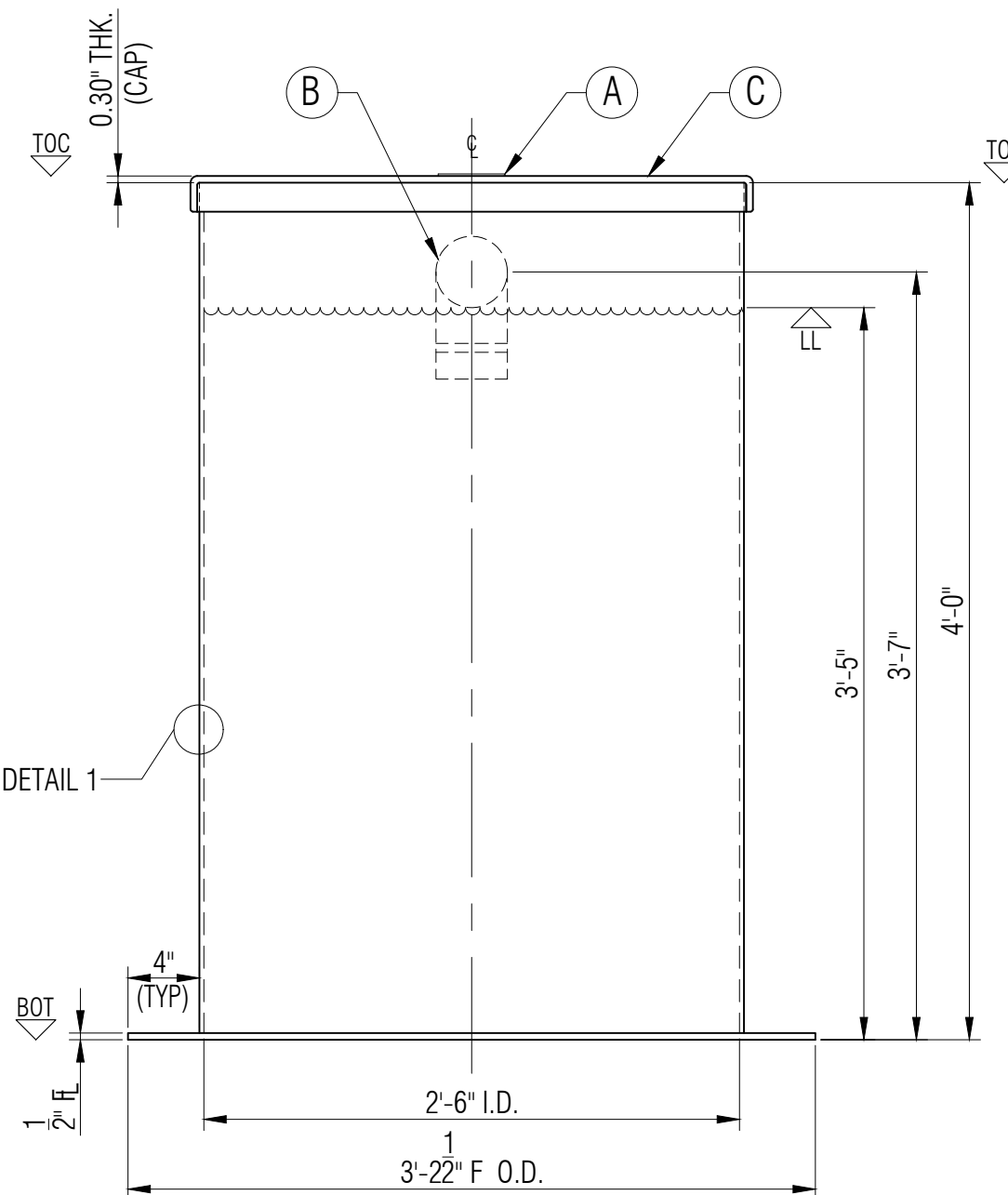

ELEVATION B

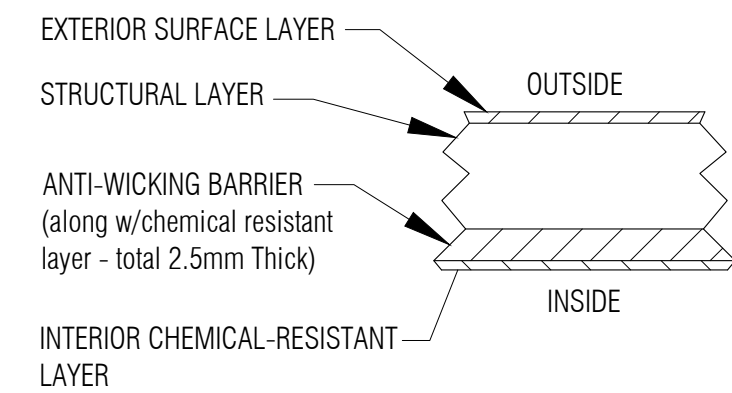

LAMINATE DETAIL 1
NTS

LEGEND:
 TOL - TOP OF LID
 TOC - TOP OF CAP
 TOT - TOP OF TANK
 BCD - BOLT CENTER DIAMETER
 BOT - BOTTOM OF TANK
 LL - LIQUID LEVEL
 I/S - INSIDE
 O/S - OUTSIDE
 Ø - DIAMETER
 ° - DEGREE/S
 TYP- TYPICAL
 CL - CENTER LINE
 NTS - NOT TO SCALE

GENERAL NOTES:
 - CSA B66 CERTIFIED FOR SEWAGE.
 - TANK COMES UNASSEMBLED FROM FACTORY.
 - TESTED TO 10'-0" BURIAL DEPTH.
 - DIMENSIONS SHOWN IN FEET INCHES FORMAT OTHERWISE NOTED.
 - 1/2" FABRICATION TOLERANCE. DOES NOT APPLY TO LAMINATE THICKNESS.

ITEM#	QTY	PART LIST/DESCRIPTION	APPROX. WEIGHT:	66 KG (145 LBS)	DRAWN:	ATF	CLIENT:	FRP/MOCOAT FIBERGLASS LTD.		
A	1	NAMEPLATE	OVERALL CAPACITY:	546 L (120IG/144 USG)	CHECKED:		TITLE:	HT30D48L FRP TANK		
B	1	4"Ø PVC - INLET			DATE:	MAR. 23, 2024	 FRP MOCOAT FIBERGLASS LTD.	SIZE	DRAWING NUMBER:	REVISION
C	1	30"Ø DETACHABLE - CAP LID			DESIGNED:			C	HT30D48L	0
D					APPROVED:	MPS	SCALE	EST#:	SO#:	SHEET
E					MFG:	DS	1:10	PO#:	JOB#:	1/1
F					PM:	GA				
G					SALES:	DG				