

**PLAN**

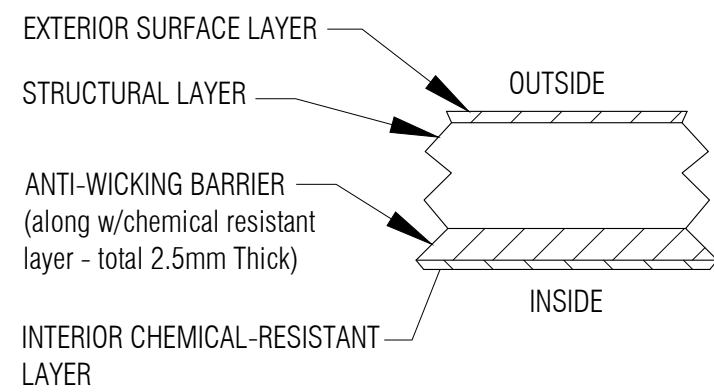

**LAMINATE DETAIL 1**  
NTS

GENERAL NOTES:  
 - CSA B66 CERTIFIED FOR SEWAGE.  
 - TANK COMES UNASSEMBLED FROM FACTORY.  
 - TESTED TO 10'-0" BURIAL DEPTH.  
 - DIMENSIONS SHOWN IN FEET INCHES FORMAT OTHERWISE NOTED.  
 - 1/2" FABRICATION TOLERANCE. DOES NOT APPLY TO LAMINATE THICKNESS.

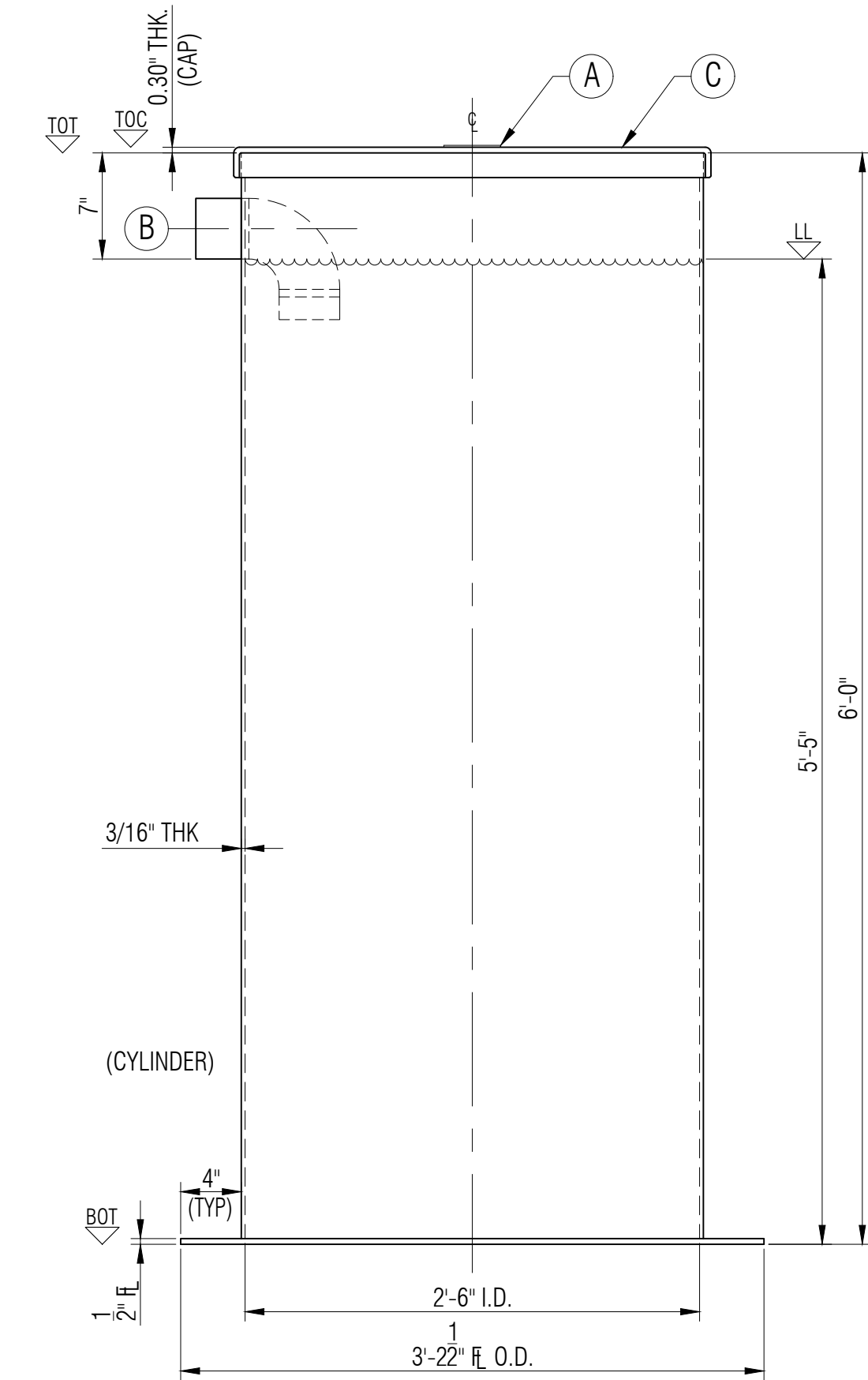

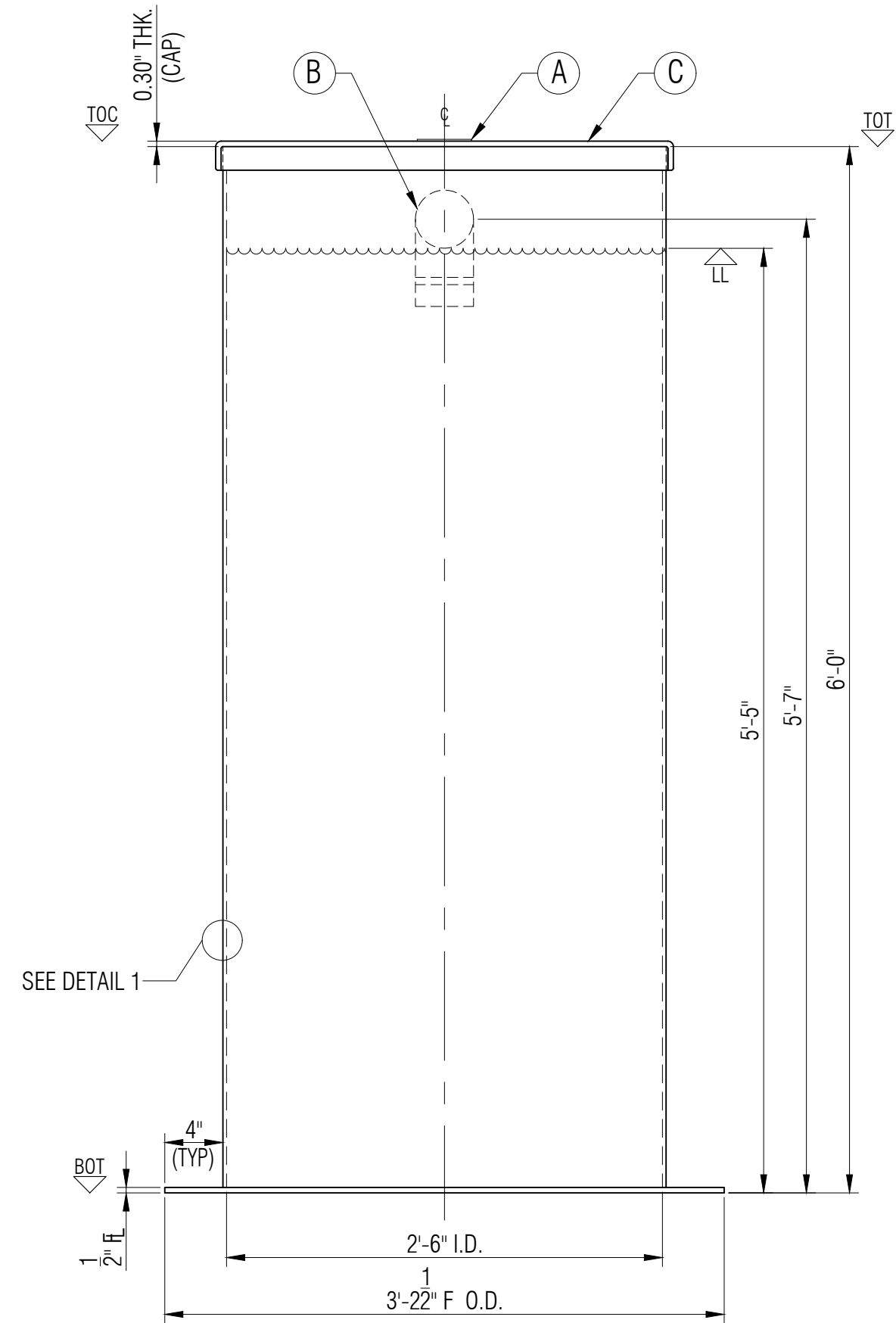

**ELEVATION A**



**ELEVATION B**

LEGEND:  
 TOL - TOP OF LID  
 TOC - TOP OF CAP  
 TOT - TOP OF TANK  
 BCD - BOLT CENTER DIAMETER  
 BOT - BOTTOM OF TANK  
 LL - LIQUID LEVEL  
 I/S - INSIDE  
 O/S - OUTSIDE  
 Ø - DIAMETER  
 ° - DEGREE/S  
 TYP - TYPICAL  
 CL - CENTER LINE  
 NTS - NOT TO SCALE

ITEM#	QTY	PART LIST/DESCRIPTION	APPROX. WEIGHT:	82 KG (180 LBS)	DRAWN:	ATF	CLIENT:	FRP/MOCOAT FIBERGLASS LTD.		
A	1	NAMEPLATE	OVERALL CAPACITY:	818 L (180 IG/216 USG)	CHECKED:		TITLE:	<b>HT30D72L FRP TANK</b>		
B	1	4"Ø PVC - INLET			DATE:	FEB. 21, 2024	  <b>FRP MOCOAT</b> FIBERGLASS LTD.	SIZE:	DRAWING NUMBER:	REVISION
C	1	30"Ø DETACHABLE - CAP LID			DESIGNED:			C	HT30D72L	0
D					APPROVED:	MPS	SCALE:	EST#:	SO#:	SHEET
E					MFG:	DS	1:10	PO#:	JOB#:	1/1
F					PM:	GA				
G					SALES:	DG				