

LABEL LOCATIONS					
ITEM	QTY	DESCRIPTION	ITEM	QTY	DESCRIPTION
A	1	NAME PLATE	B	1	INLET
C	1	OUTLET	D	1	DANGER GAS
E	2	LIFTING HANDLE			
* TANK COMES FULLY ASSEMBLED FROM FACTORY *					
* PVC FITTINGS ARE CSA CERTIFIED					

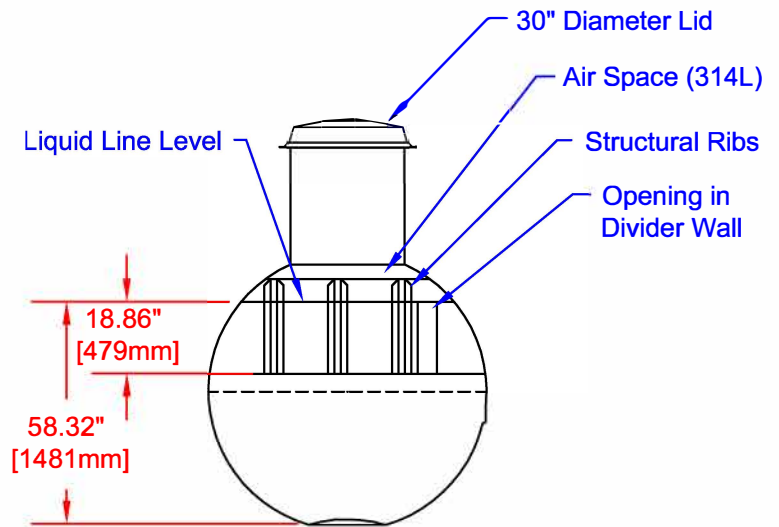
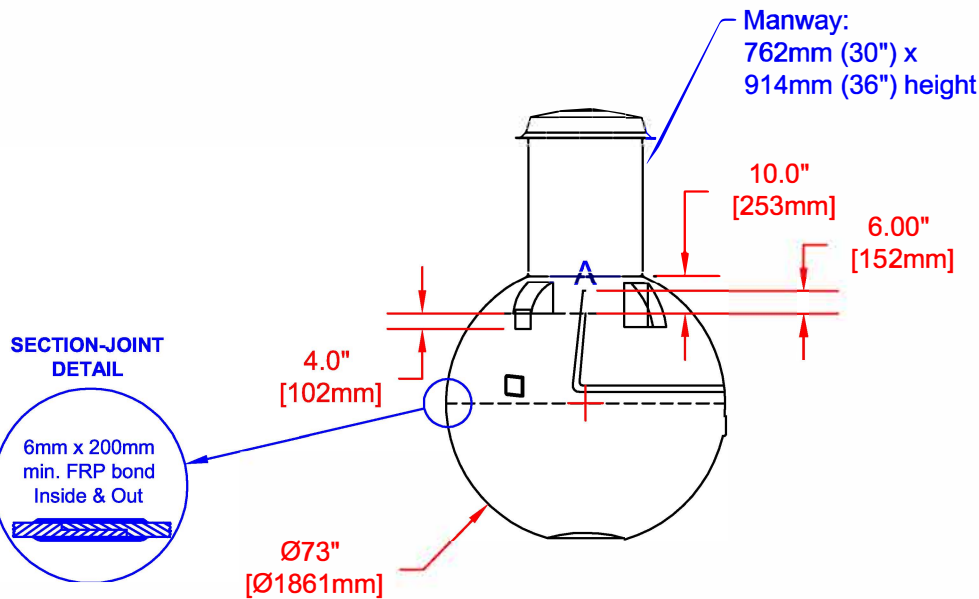
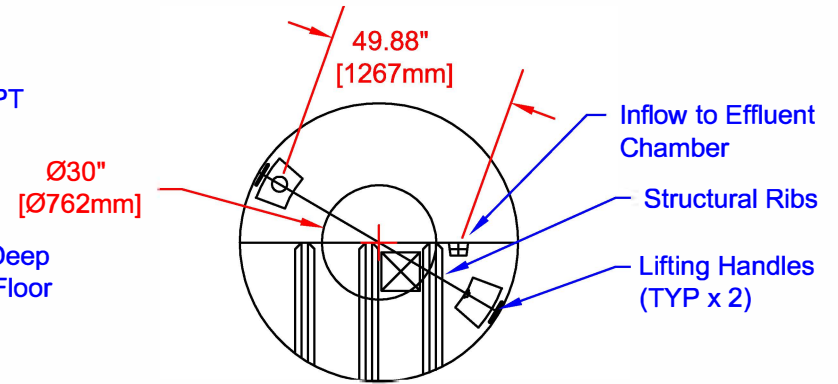
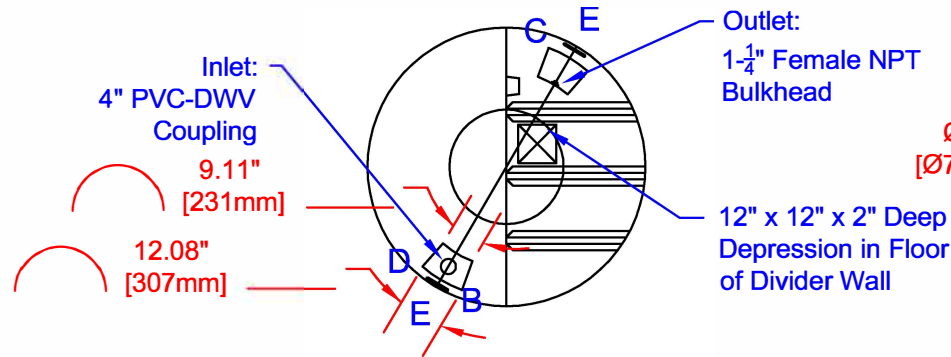

PB750 FIBREGLASS PUMP-OUT SEWAGE TANK

Overall Diameter:	1,854mm (73")	Overall Weight:	136 kg (300 lbs)	Overall Capacity:	3,337L (734 Imp Gal, 881 US Gal)
DATE:	07-13-2022	DATE:		DWG SCALE:	Septic Chamber: 2500L (550 Imp Gal, 660 US Gal)
BY:	MARK SOLLID	APPROVAL:		REV:	A
					Effluent Chamber: 486L (107 Imp Gal, 128 US Gal)