

30" D Lid

LABEL LOCATIONS					
ITEM	QTY	DESCRIPTION	ITEM	QTY	DESCRIPTION
A	1	NAME PLATE	B	1	INLET
C	1	OUTLET	D	1	DANGER GAS
E	2	LIFTING HANDLE			

* TANK COMES FULLY ASSEMBLED FROM FACTORY
 * PVC FITTINGS ARE CSA CERTIFIED

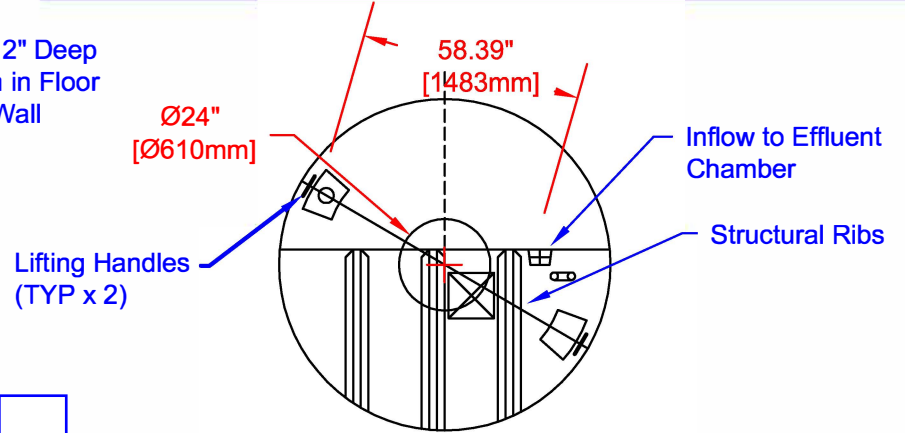
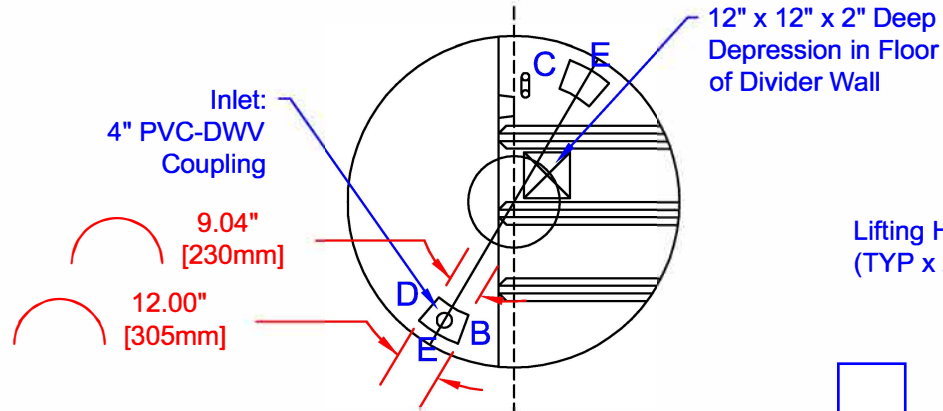

30" D X 36" H

SECTION-JOINT DETAIL

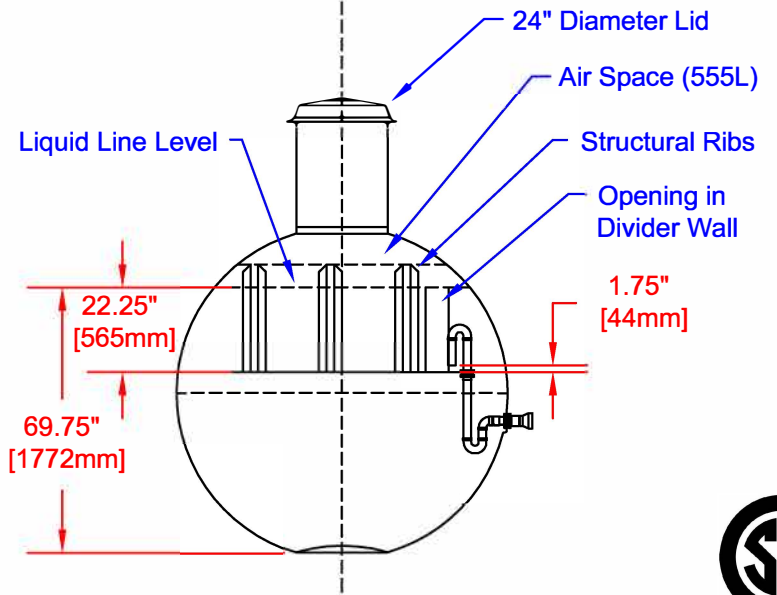
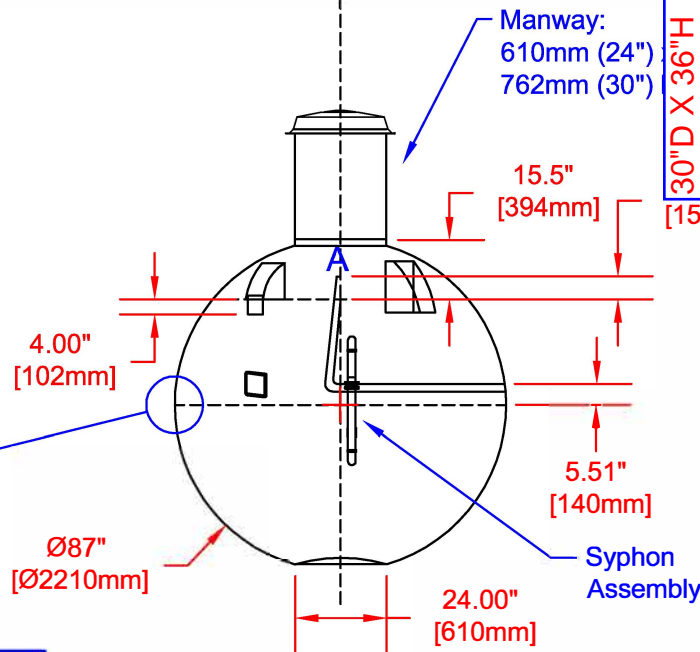

FRP MOCOAT

SB1000 FIBREGLASS SYPHON SEWAGE TANK

Overall Diameter:	2,210mm (87")	Overall Weight:	182kg (400lbs)	Overall Capacity:	5,655L (1,244 Imp Gal, 1,493 US Gal)
DATE:	07-13-2022	DATE:		Septic Chamber:	4320L (950 Imp Gal, 1,140 US Gal)
BY:	MARK SOLLID	APPROVAL:		Effluent Chamber:	841L (185 Imp Gal, 222 US Gal)
			REV: A	Flush:	727L (160 Imp Gal, 192 US Gal)