

LABEL LOCATIONS					
ITEM	QTY	DESCRIPTION	ITEM	QTY	DESCRIPTION
A	1	NAME PLATE	B	1	INLET
C	1	OUTLET	D	1	DANGER GAS
E	2	LIFTING HANDLE			

* TANK COMES FULLY ASSEMBLED FROM FACTORY *

* PVC FITTINGS ARE CSA CERTIFIED

LAMINATE DETAIL



Note:
5" x 5" Flat Bumpout that is 4" below Horizontal C.L.

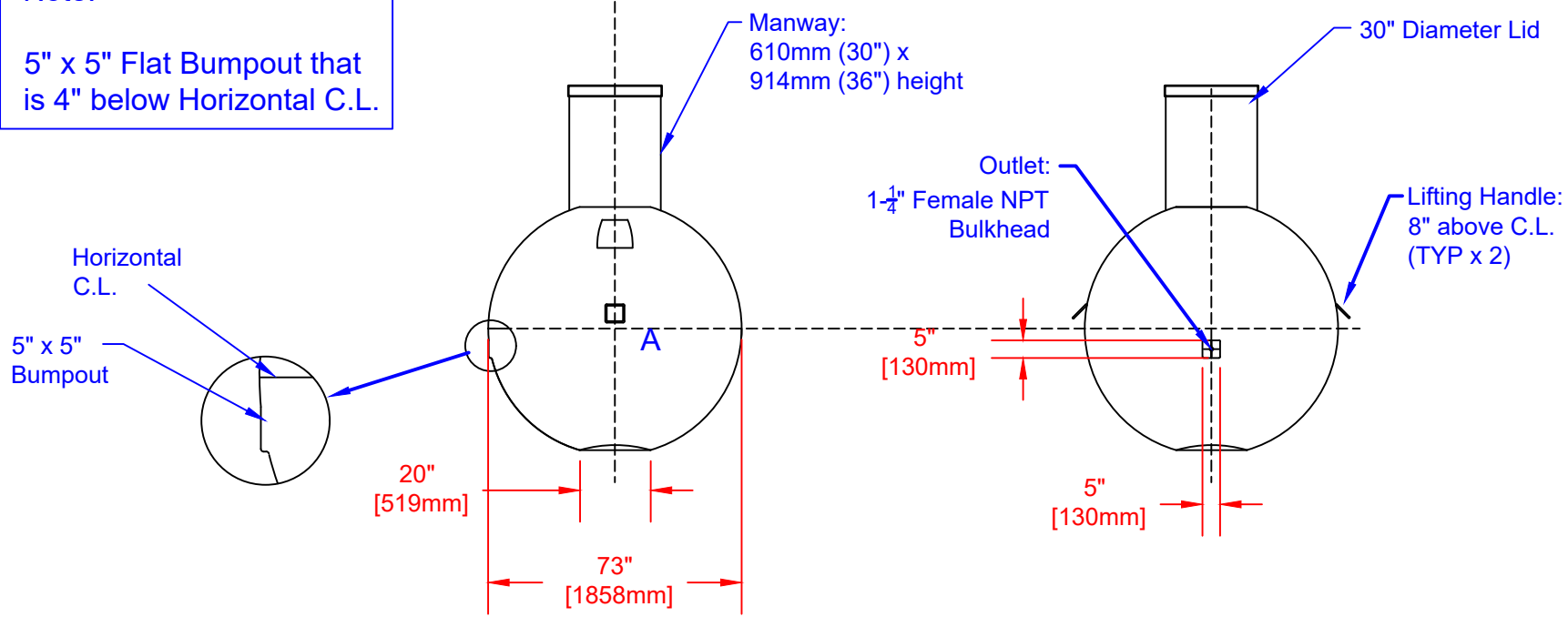

Drinking Water
NSF/ANSI 61

FRP
MOCOAT

WB750 FIBREGLASS WATER CISTERN

DATE: 06-27-2022	DATE:	DWG SCALE:	Overall Diameter:	1,854mm (73")
BY: MPS	APPROVAL:	REV: A	Approx. Weight:	136kg (300lbs)
			Holding Capacity:	3,337L (734 Imp Gal, 881 US Gal)